

Obtaining the Wild bergamot essential oil with high content of thymoquinone

^{*}Igor Casian, Ana Casian, Vladimir Valica

Scientific Centre for Medicinal Plants Cultivation
Nicolae Testemitanu State University of Medicine and Pharmacy
Chisinau, the Republic of Moldova

Authors' ORCID iDs, academic degrees and contributions are available at the end of the article

^{*}Corresponding author: kasyan_i@yahoo.com

Manuscript received May 18, 2020; revised manuscript June 07, 2020; published online June 10, 2020

Abstract

Background: The Wild bergamot (*Monarda fistulosa* L.) is mentioned among plants with high content of thymol and carvacrol in the composition of essential oil. At the same time, it also produces significant amounts of thymoquinone – a substance with antimycotic, anticancerous and antituberculous activity. The objective of this study was to evaluate the factors which affect the thymoquinone formation during the processing of plant material, and to create a technological procedure for obtaining the Wild bergamot essential oil with maximum content of this active compound.

Material and methods: Aerial parts of the Wild bergamot have been harvested in the budding-flowering phase from the collection of the Scientific Centre for Medicinal Plants Cultivation of Nicolae Testemitanu State University of Medicine and Pharmacy. Essential oil isolation has been performed by hydrodistillation. Analysis of plant material and the obtained samples of essential oil have been performed by high performance liquid chromatography method with diode-array UV detection.

Results: The content of thymoquinone increases considerably during the process of fermentation of humidified plant material in the air stream prior to the essential oil distillation. Additionally, the content of thymoquinone in the essential oil can be increased by performing the distillation with a mixture of steam and air.

Conclusions: A technological procedure was created, which allowed obtaining the Wild bergamot essential oil, that contains 20-32% of thymoquinone and 23-32% of thymol and carvacrol, with a yield of 12.5-14.5 g from 1 kg of dried plant material.

Key words: *Monarda fistulosa* L., essential oil, thymoquinone, hydrodistillation.

Cite this article

Casian I, Casian A, Valica V. Obtaining the Wild bergamot essential oil with high content of thymoquinone. *Mold Med. J.* 2020;63(2):40-43. doi: 10.5281/zenodo.3866012.

Introduction

Bacterial resistance to the majority of traditionally used antibiotics requires searching for new products with antimicrobial action [1, 2]. One of the directions of this searching are aromatic plants, which have a broad spectrum of actions, including antimicrobial ones [3, 4]. The genus *Monarda*, family *Lamiaceae*, is mentioned among these plants. Their species have been introduced into culture in many countries [5, 6], including the Republic of Moldova [7]. Phyto-chemical studies of *Monarda fistulosa* L. and *Monarda didyma* L. indicate the presence, in the essential oil, of high amounts of phenolic compounds (thymol and carvacrol) – up to 60-70% [8, 9].

Some sources indicate that the Wild bergamot essential oil also contains thymoquinone and thymohydroquinone [10, 11]. Their antimycotic, anticancerous and antituberculous actions were demonstrated both *in vitro* and *in vivo* [12-15].

However, according to our data, the thymoquinone content in the Wild bergamot essential oil, obtained by the traditional methods, is relatively low (not more than 3-4%).

This depends on plant material drying and storage conditions, as well as technological parameters of the essential oil isolation process. Prior studies have described a method for intensification of the thymoquinone accumulation, based on some agrotechnical procedures [16]. However, we could not find any indications about the possibility to increase thymoquinone formation after the plant material harvesting. As a consequence, the objective of this study was to evaluate the factors which affect the thymoquinone formation during the processing of plant material, and to create a technological procedure for obtaining the Wild bergamot essential oil with maximum content of this active compound.

Material and methods

Plant material. Aerial parts of the Wild bergamot have been harvested in the budding-flowering phase from the collection of the Scientific Centre for Medicinal Plants Cultivation of Nicolae Testemitanu State University of Medicine and Pharmacy.

Apparatus. Essential oil isolation has been performed by hydrodistillation, using a laboratory-made installation, as-

sembled from peristaltic pump with adjustable speed of 0.5-1.0 L/h, flow evaporator with maximal electric power of 0.35 kW, cylindrical extractor with internal volume of 0.5 L, 2.8 L or 4.5 L and flow cooler. Analysis of plant material, as well as of the obtained samples of the Wild bergamot essential oil has been performed using *Agilent 1260* liquid chromatograph with diode-array UV detector. The following chromatographic conditions were used: analytical column *Zorbax Eclipse Plus C18*, 3.5 mm, 4.6 x 100 mm at 30°C; mobile phase: acetonitrile – 0.1% acetic acid solution (50:50), debit 1.2 mL/min; detection at 256 nm (thymoquinone) and 276 nm (thymol, carvacrol and thymohydroquinone).

Chemicals. In the study have been used reference substances: Thymol, Carvacrol and Thymoquinone (*Sigma-Aldrich*). Thymohydroquinone was obtained *in situ* as a product of thymoquinone reduction by ascorbic acid. Other reagents of analytical grade have been purchased from *Sigma-Aldrich Chemie GmbH* and *Merck* (Germany).

Results and discussion

As a “starting point”, we have obtained the essential oil from fresh herb of Wild bergamot, using the traditional method of hydrodistillation. Ideally, the time interval from plant material harvesting and the essential oil distillation should be as short as possible, because the enzymatic oxidation of volatile phenols takes place at the storage of collected aerial parts. From each kilogram of plant material, loaded into the extractor of 4.5 L volume, we have obtained 6-7 g of essential oil. This product contains 40-60% of phenolic compounds (sum of thymol and carvacrol) and not more than 0.3% of thymoquinone. At storage the thymoquinone content decreases to about 0.05%. If initial value is overstated due to notable degree of fermentation, may appear an inconsiderable crystalline precipitate. This needs to be separated by decanting and filtration.

Obtained product presents an oily liquid of light-yellow to yellow colour, with a strong odour and spicy taste, specific for the Wild bergamot. It is soluble in 3-18 parts of 70% ethanol. Relative density is 0.909 to 0.929, refraction index – 1.490 to 1.505, dry residue – not more than 1%.

At drying of the Wild bergamot herb a significant part of thymol and carvacrol transforms into thymoquinone. It is due to high activity of oxidative enzymes. But at the essential oil distillation from dried plant material, a major part of thymoquinone reduces to thymohydroquinone by different reducing substances present in the raw material. As a result, the thymoquinone content in essential oil, obtained from dried plant material, usually does not exceed 3-4% and continues to decrease during storage, sometimes practically to disappearance. Simultaneously, a considerable amount of thymohydroquinone forms as a crystalline precipitate.

To increase the thymoquinone yield at obtaining of the Wild bergamot essential oil, we have introduced two modifications into technological procedure:

1. *Additional fermentation of plant material prior to distillation.* With the purpose to reactivate enzymes, the dried

plant material was humectated with water, then exposed to air fermentation. This process may be carried out on opened trays with periodical mixing, but more technological is to perform the fermentation with a continuous air stream, blowing through the humidified plant material, loaded into the distillation extractor. The main advantage of this approach is the use of one apparatus at two technological stages without reloading the plant material. In this phase of the study were optimized such parameters as amount of water, debit of air, temperature and duration of fermentation.

2. *Distillation of the essential oil with a mixture of air and steam.* This idea is based on the fact that oxygen protects the thymoquinone from reduction during the distillation. The air was pumped together with water into the mixer, connected to the inlet of the flow evaporator (fig. 1). The volume of the extractor was decreased to 2.8 L, because it was found, that high duration of the distillation process leads to decreasing of the thymoquinone yield due to its reduction to thymohydroquinone.

This approach has allowed obtaining the essential oil with thymoquinone content of 20-32% vs. 9-17% at steam distillation without air adding. We have obtained samples of essential oil with high thymoquinone content (up to 38%), using an extractor of small volume (0.5 L). This content was not depending significantly on the presence of air in steam, due to fast increasing of temperature in the extractor and short time of distillation process. However, both small amounts of raw material used (about 75 g) and essential oil obtained (1.1-1.5 g) in each load, have made this variant of low efficiency.

As a result of the study, the following laboratory procedure has been elaborated to obtain the Wild bergamot essential oil with high content of thymoquinone:

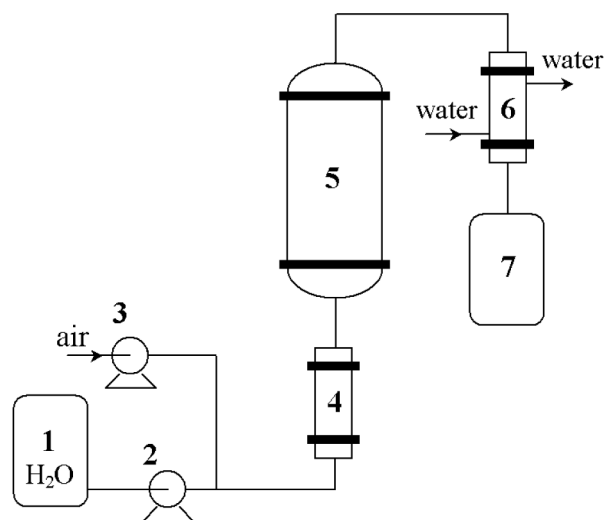

Fig. 1. Scheme of the laboratory installation for isolation of essential oil.

- 1 – feeding vial with water, 2 – water pump, 3 – air pump, 4 – electric flow evaporator, 5 – extractor with plant material, 6 – flow cooler, 7 – recipient for condensate.

Humectate 0.35 kg of the Wild bergamot herb, dried and fragmented, with 0.7 L purified water and mix thoroughly then load into a cylindrical extractor of 2.8 L volume. Keep the extractor at $35^{\circ}\text{C} \pm 2^{\circ}\text{C}$ and blow with air, using a membrane pump, at 1.0-1.2 L/min for 6 h. Connect the extractor with a flow evaporator of 0.35 kW power and pump to the inlet of the evaporator water at 500-550 mL/h together with atmospheric air at 1.5 L/min at the start of process and 1.0 L/min after appearance of distillate from the flow cooler, connected to the outlet of the extractor. Upon termination of the distillation blow the extractor with steam only, to wash down the stratum of essential oil, deposited on the walls of the cooler. Collect about 250 mL of distillate into a narrow-necked flask, and then separate the layer of essential oil.

The yield of essential oil, obtained by the described method, was 4.4-5.1 g from a load of the extractor, or 12.5-14.5 g from one kilogram of dried raw material.

The product presents an oily liquid of dark orange-brown colour, with strong odour and spicy taste specific for the Wild bergamot. It is soluble in 4-10 parts of 70% ethanol. Relative density is 0.940 to 0.970, refraction index – 1.498 to 1.514. The essential oil contains 23-32% sum of thymol and carvacrol and 20-32% of thymoquinone. During storage the thymoquinone concentration decreases by 3-4%, and then stabilizes. At storage on light the colour becomes darker, and the thymoquinone content decreases.

At the initial period of storage of the Wild bergamot essential oil, independently of the technological procedure's parameters, thymoquinone reacts with reducing compounds presented in the product. This results into the thymohydroquinone formation. This process has a diphasic character: the thymoquinone concentration quickly decreases during the first week, and stabilization of the composition takes place after about a month of storage. The process kinetics can be formalized with the biexponential model type: $C = C_0 + A_1 \cdot e^{(-t/k_1)} + A_2 \cdot e^{(-t/k_2)}$. For this reason we suggest storing the obtained oil for a month in quarantine before use. After expiration of this period the product composition remains stable for at least 2 years at storage in hermetic glass containers.

Conclusions

A laboratory technological procedure has been elaborated for obtaining the Wild bergamot essential oil with high thymoquinone content. This procedure is based on the air-stream fermentation of plant material, humectated with water, prior to distillation, and on distillation of essential oil with a mixture of steam and air. The thymoquinone content was 20-32% with the essential oil yield of 12.5-14.5 g from 1 kg of plant material.

References

1. Oniga O, Nastasă C, Ionuț I, Stana A, Oniga S, Tiperciuc B. Recent developments in antibacterial antibiotics. *Revista Farmaceutica a Moldovei*. 2016;(1-4):42-50.
2. Prestinaci F, Pezzotti P, Pantosti A. Antimicrobial resistance: a global multifaceted phenomenon. *Pathog Glob Health*. 2015;109(7):309-318. doi: 10.1179/204773215Y.0000000030.
3. Mickienė R, Bakutis B, Maruška A, Ragažinskienė O, Kaškonienė V. Effect of the volatile secondary metabolites of *Monarda didyma* L., *Lamium album* L. and *Myrrhis odorata* L. Plants against micromycetes of indoor environments of animals [Internet]. *Veterinarija ir Zootechnika*. 2014;68(90):48-54. [cited 2020 Apr 20]. Available from: <https://vetzoo.lsmuni.lt/data/vols/2014/68/pdf/mickiene.pdf>
4. Oniga I, Benedec D, Toiu A, Hanganu D. Produse naturale cu acțiune antimicrobiană [Natural products with antimicrobial activity]. *Revista Farmaceutică a Moldovei*. 2016;(1-4):51-54. Romanian.
5. Bedulenko MA. Introduktsiia, ekologicheskii aspekt i sovremennye napravleniia izucheniia i primeneniia lekarstvennogo, priano-aromaticheskogo i efirnomaslichnogo rasteniia *Monarda fistulosa* L. [Introduction, ecological aspect and modern directions of studying and application of medicinal, spicy aromatic and essential oil plant *Monarda fistulosa* L.]. *Trudy Belorusskogo gosudarstvennogo universiteta*. 2013;8(2):52-60. [cited 2020 Apr 20]. Available from: <http://elib.bsu.by/bitstream/123456789/103585/1/2013-8-2-52-60.pdf>. Russian.
6. Svydenko LV, Korablova OA, Svydenko SV. Selektiia i issledovanie *Monarda didyma* L. i *Monarda fistulosa* L. v Ukraine [Selection and research of *Monarda didyma* L. and *Monarda fistulosa* L. in Ukraine]. In: *Sbornik nauchnykh trudov Mezhdunarodnoi nauchno-prakticheskoi konferentsii "Biologicheskie osobennosti lekarstvennykh i aromaticheskikh rastenii i ikh rol' v meditsine"*, posviashchennoi 85-letiiu VILAR [[Proceedings of the International Scientific conference "Biological peculiarities of medicinal and aromatic plants and their significance for medicine", dedicated to the 85th anniversary of VILAR]. Moscow; 2016. p. 153-155. Russian.
7. Bodrug MV. Introduktsiia novykh efirnomaslichnykh rastenii v Moldove [Introduction of new species of essential oil plants in Moldova]. *Kishinev: Shtiintsa*; 1993. p. 96-159. Russian.
8. Oparin RV, Pokrovskii LM, Vysochina GI, Tkachev AV. Issledovanie khimicheskogo sostava efirnogo masla *Monarda fistulosa* L. i *Monarda didyma* L., kul'tiviruemykh v usloviakh Zapadnoi Sibiri [Study of the chemical composition of essential oil of *Monarda fistulosa* L. and *Monarda didyma* L., cultivated in conditions of Western Siberia]. *Khimiia Rastitel'nogo Syr'ia*. 2000;(3):19-24. Russian.
9. Vishnevskaia OE, Shavarda AL, Solovieva AE, Zvereva OA. Issledovanie komponentnogo sostava efirnogo masla rastenii roda *Monarda* (*Lamiaceae*), kul'tiviruemykh v usloviakh Severo-Zapadnogo Regiona [Study of the essential oil composition of plants of the genus *Monarda* (*Lamiaceae*), cultivated in the North-West region]. *Agrarnaia Rossiia*. 2006;(6):60-63. Russian.
10. Taborsky J, Kunt M, Kloucek P, Lachman J, Zeleny V, Kokoska L. Identification of potential sources of thymoquinone and related compounds in *Asteraceae*, *Cupressaceae*, *Lamiaceae*, and *Ranunculaceae* families. *Cent Eur J Chem*. 2012;10(6):1899-1906. doi: 10.2478/s11532-012-0114-2.
11. Nikitina AS, Aliev AM, Fes'kov SA, Nikitina NV. Komponentnyi sostav efirnogo masla travy *Monarda fistulosa* L. iz kolektsii Nikitskogo botanicheskogo sada [Component composition of essential oil of *Monarda fistulosa* L. grass from the collection of Nikitsky botanical garden]. *Khimiia Rastitel'nogo Syr'ia*. 2018;(2):55-62. doi: 10.14258/jcprm.2018023295. Russian.
12. Inouye S, Takahashi M, Abe S. Inhibitory activity of hydrosols, herbal teas and related essential oils against filament formation and the growth of *Candida albicans*. *Jpn J Med Mycol*. 2009;50(4):243-252. doi: 10.3314/jjmm.50.243

13. Ivankovic S, Stojkovic R, Jukic M, Milos M, Milos M, Jurin M. The antitumor activity of thymoquinone and thymohydroquinone *in vitro* and *in vivo* [Internet]. *Exp Oncol*. 2006;28(3):220-224 [cited 2020 Apr 20]. Available from: <https://www.researchgate.net/publication/6716660>
14. Kouidhi B, Zmantar T, Jrah H, Souiden Y, Chaieb K, Mahdouani K, Bakhrouf A. Antibacterial and resistance-modifying activities of thymoquinone against oral pathogens. *Ann Clin Microbiol Antimicrob*. 2011;10:29. doi: 10.1186/1476-0711-10-29.
15. Randhawa MA. *In vitro* antituberculous activity of Thymoquinone, an active principle of *Nigella sativa*. *J Ayub Med Coll Abbottabad* [Internet]. 2011;23(2):78-81 [cited 2020 Apr 20]. Available from: <http://www.ayubmed.edu.pk/JAMC/23-2/Randhawa.pdf>.
16. Rohlfesen WG, inventor. Method for cultivation of *Monarda fistulosa* for production of thymoquinone. United States patent US 9,073,824 B2. 2015 Jul 7.

Authors' ORCID iDs and academic degrees

Igor Casian, MD, Pharm PhD, Research Associate Professor of Pharmacy – <https://orcid.org/0000-0001-6392-3804>.

Ana Casian, MD, Pharm PhD, Research Associate Professor of Pharmacy – <https://orcid.org/0000-0001-8876-3691>.

Vladimir Valica, MD, Pharm PhD, Professor of Pharmacy – <https://orcid.org/0000-0002-1068-5504>.

Authors' contributions

IC designed the study, conducted the laboratory work and performed its technological part, interpreted the data, drafted the first manuscript. AC collected and processed the plant material, performed the analytical part of the laboratory work. VV interpreted the data, revised the manuscript. All the authors revised and approved the final version of the manuscript.

Funding

This study was supported by *Nicolae Testemitanu* State University of Medicine and Pharmacy. The trial was the authors' initiative. The authors are independent and take responsibility for the integrity of the data and accuracy of the data analysis.

Ethics approval and consent to participate

No approval was required for this study.

Conflict of Interests

No competing interests were disclosed.

